

Portable Scale

Instruction Manual

SOLO models covered in this manual

TAJ203	200ct x 0.005ct (40g x 0.001g)
TAJ202	210g x 0.01g
TAJ402	410g x 0.01g
TAJ602	610g x 0.01g
TAJ501	500g x 0.1g
TAJ2001	2000g x 0.1g
TAJ4001	4000g x 0.1g
TAJ6000	6000g x 1g
TA152	150g x 0.01g
TA302	300g x 0.01g
TA301	300g x 0.1g
TA501	500g x 0.1g
TA1501	1500g x 0.1g
TA3000	3000g x 1g
SLF103	100g x 0.001g
SLF152	150g x 0.01g
SLF302	300g x 0.01g
SLF301	300g x 0.1g
SLF501	500g x 0.1g
SLF901	900g x 0.1g
SLF1501	1500g x 0.1g
SLF3001	3000g x 0.1g
SLF5000	5000g x 1g
SLY103	100g x 0.001g
SLY152	150g x 0.01g
SLY302	300g x 0.01g
SLY301	300g x 0.1g
SLY501	500g x 0.1g
SLY901	900g x 0.1g
SLY1501	1500g x 0.1g
SLY3001	3000g x 0.1g
SLY5000	5000g x 1g

SLW103	100g x 0.001g
SLW152	150g x 0.01g
SLW302	300g x 0.01g
SLW301	300g x 0.1g
SLW501	500g x 0.1g
SLW901	900g x 0.1g
SLW1501	1500g x 0.1g
SLW3001	3000g x 0.1g
SLW5000	5000g x 1g
SLC103	100g x 0.001g
SLC152	150g x 0.01g
SLC302	300g x 0.01g
SLC301	300g x 0.1g
SLC501	500g x 0.1g
SLC1501	1500g x 0.1g
SLC3001	3000g x 0.1g
SLC5000	5000g x 1g
SLN103	100g x 0.001g
SLN152	150g x 0.01g
SLN301	300g x 0.1g
SLN901	900g x 0.1g
SLP202	200g x 0.01g
SLP501	500g x 0.1g
SLP1001	1000g x 0.1g
SLP3000	3000g x 1g
SLS302	300g x 0.01g
SLS502	500g x 0.01g
SLS1501	1500g x 0.1g
SLS3001	3000g x 0.1g
SLS6001	6000g x 0.1g

Mark	Standard
	This product conforms to the EMC Directive 89/336/EEC and the Low Voltage Directive 73/23/EEC. The complete Declaration of Conformity is available from your authorized dealer.



Disposal

In conformance with the European Directive 2002/96 EC on Waste Electrical and Electronic Equipment (WEEE) this device may not be disposed of in domestic waste. This also applies to countries outside the EU, per their specific requirements.

Please dispose of this product in accordance with local regulations at the collecting point specified for electrical and electronic equipment.

If you have any questions, please contact the responsible authority or the distributor from which you purchased this device.

Should this device be passed on to other parties (for private or professional use), the content of this regulation must also be related.

Thank you for your contribution to environmental protection.

FCC Note

This equipment has been tested and found to comply with the limits for a Class B digital device, pursuant to Part 15 of the FCC Rules. These limits are designed to provide reasonable protection against harmful interference in a residential installation. This equipment generates, uses and can radiate radio frequency energy and, if not installed and used in accordance with the instructions, may cause harmful interference to radio communications. However, there is no guarantee that interference will not occur in a particular installation. If this equipment does cause harmful interference to radio or television reception, which can be determined by turning the equipment off and on, the user is encouraged to try to correct the interference by one or more of the following measures:

- Reorient or relocate the receiving antenna.
- Increase the separation between the equipment and receiver.
- Connect the equipment into an outlet on a circuit different from that to which the receiver is connected.
- Consult the dealer or an experienced radio/TV technician for help

Industry Canada Note

This Class B digital apparatus complies with Canadian ICES-003.

Cet appareil numérique de la classe B est conforme à la norme NMB-003 du Canada.

1. INTRODUCTION

This manual contains installation, operation and maintenance instructions. Please read the manual completely before using the scale.

1.1 Safety Precautions

Please follow these safety precautions:

- Verify that the Power Adapter input voltage matches the local power supply voltage.
- Use the scale only in dry locations.
- Do not operate the scale in hostile environments.
- Do not drop loads on the pan.
- Do not place the scale upside down on the pan.
- Service should be performed only by authorized personnel.

1.2. Controls

TABLE 1-1. CONTROL FUNCTIONS.

Key Name	Function
On-Zero Off Yes*	• Primary function (Short Press) – If scale is Off, turn On. If scale is on, perform Zero/Tare function
	• Secondary function (Long Press) – Turn scale Off
	• Menu function – (Yes) This key is used to accept the currently displayed setting
Print Cal*	• Primary function (Short Press) – Send the current display value to serial port if installed
	• Secondary function (Long Press) – Starts Span calibration as available in Menu
Unit No*	• Primary function (Short Press)– Advances to next available unit
	• Menu function – (No) This key is used to reject the displayed setting and advance to next available setting

*The actual text may vary on some models though the functionality is the same.

2. INSTALLATION

2.1 Package Contents

- Scale
- Pan
- Draft Shield
- Power Adapter
- Instruction Manual

2.2. Location

Use the scale on a firm, steady surface. Avoid locations with excessive air currents, vibrations, heat sources, or rapid temperature changes.

2.3. Transportation Lock, Calibration Lock & Pan Installation

Before using the scale the Transportation Lock must be released. At the bottom of the scale slide the locking pin to the  position. See Figures 2-1.

If the scale is to be calibrated by the user ensure that the Calibration Lock is set to the  position. See Figure 2-2.

Install the metal pan over the plastic sub-platform.

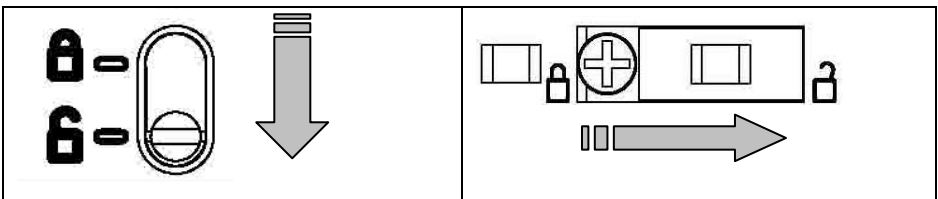
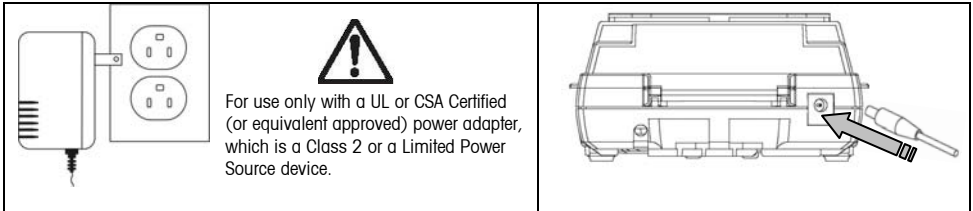

Figure 2-1. Release Transportation Lock

Figure 2-2. Release Calibration Lock

2.4 Connect Power

A Power Adapter is used to power the scale. Connect the Power Adapter to the power outlet (see Figure 2-3) and the power plug to the back of the scale (see Figure 2-4)



Figures 2-3, Power Adapter

Figure 2-4, Power Plug

2.5 Battery Installation and Use

The scale may also be powered by batteries. Remove the battery cover and install four alkaline AA (LR6) type batteries, (not included). Refer to Figure 2.5 to properly install the batteries. Under battery power a battery symbol is shown on the left side of the display. The Auto-Off setting is useful for conserving battery power, see section 4.2.1.

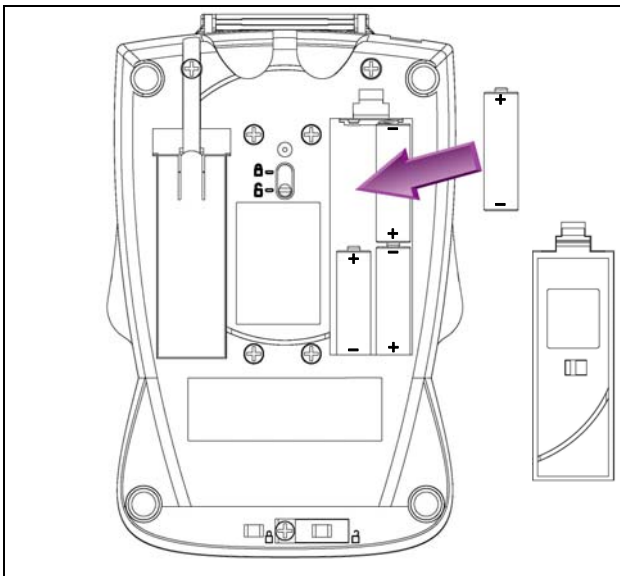

Figure 2-5, Battery Installation.

2.6 Initial Calibration

Power on the scale by pressing **On-Zero**. Allow at least one minute for the scale to stabilize before calibrating. Press and hold the **Print/Cal** button until [CAL] is displayed. The display flashes [-C-] while zero reading is taken. The display flashes the required span mass. Put the indicated calibration mass on the pan and press **On-Zero**. The display flashes[-C-]. When calibration is complete, [DONE] is displayed.

Note: Calibration is also available in the Setup menu, see section 4.2.1.

3. OPERATION

Note that one or more weighing Units of measure may initially be unavailable. They can be enabled in the Main menu Unit [U.n. 1.2], see section 4.2.2.

3.1 Draft Shield

The draft shield was designed with an easy to remove center piece which can be used as a high quality sample tray. Even with the center piece removed the draft shield will provide increased protection from rough environments while maintaining weighing speed. To remove the center piece, rotate counter-clockwise. See Figure 3-1. With the sample tray firmly in place the unique shape of the draft shield also allows for efficient stacking of one scale on top of another.

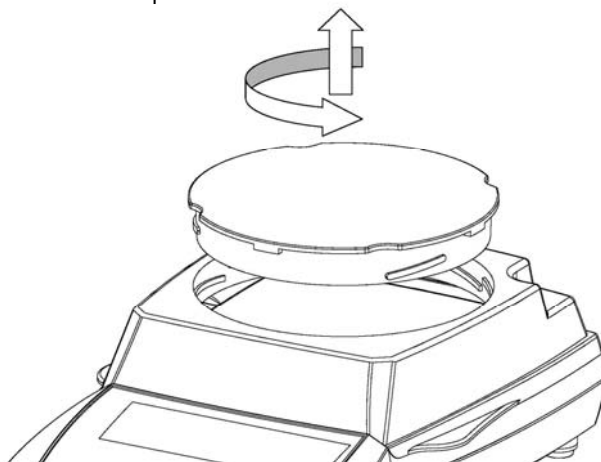

Figure 3.1, Sample Tray Removal

3.2 Weighing Mode

Press **Unit** to advance to next available weighing Unit.

Press **Zero** to zero the scale and then place objects to be weighed on the pan.

4. SETTINGS

The Settings allow the user to customize the scale.

4.1 Menu Structure

Table 4-1 illustrates the menu structure.

TABLE 4-1 MENU

<u>S.E.t.u.P</u>	<u>U.n.i.t.</u>	<u>E.n.d.</u>
A-OFF On OFF	U.n.i.t g On OFF	Press Yes or No
SPAN Press Yes or No	U.n.i.t N On OFF	
Lin Press Yes or No	End Press Yes or No	
End Press Yes or No		

Notes:

Unit	Symbol	Factor
Gram	g	1
Newton	N	9.806e-3

Default menu settings are shown in **bold**.

Press the **On** button for **Yes**.

Press the **Unit** button for **No**.

4.2 Menu Navigation

Main level menus are identified by decimal points between each letter, for example [S.E.t.u.P].

Enter Menu: The Menus may be entered at power up by holding down the **On** button until [S.E.t.u.P] is displayed. Each main menu is entered by pressing the **On** button for a **Yes**. Advance to the next main menu by pressing the **Unit** button as a **No**.

Changing Settings: Within each main menu are sub-menus. Enter each sub-menu by pressing the **On** button for a **Yes**. Advance to the next sub-menu by pressing the **Unit** button as a **No**. To accept the displayed sub-menu setting, press **Yes**. To advance to the next setting, press **No**.

Menu Exit: The last item in each sub-menu is [End]. Pressing **Yes** will return to the main level menu. The last item in the main menu is [End]. Pressing **Yes** will return to the weighing mode.

4.2.1 Setup Menu [S.E.E.U.P.]

The Setup menu contains the following sub-menus:

Auto-Off [A-OFF]:

Auto Off settings: **On OFF**

Setting [00] will automatically turn the scale off after no activity is detected for 4 minutes.

Span Calibration [SPAN]:

Uses two weight values: Zero and a value at or near the full capacity of the scale. Span calibration should be performed if the scale is repositioned or if the room temperature changes significantly.

Linearity Calibration [L IN]:

Uses three weight values: Zero, a mid-range value and full capacity. Generally this calibration is not required unless testing shows that the linearity error exceeds the linearity tolerance in the specification table. Accuracy of the weights is important to maintain weighing integrity.

4.2.2 Unit Menu [U.N. U.]

Each Weighing Unit may be individually set to **On** or **OFF**.

See Table 4-1 for the symbols associated with each Unit or Mode.

4.2.3 Other Menus

Additional Menus are available if a serial interface option is installed in the scale. These menus are explained within the user manual of each option kit.

4.3. Calibration Lock Feature

Sliding the switch fully to the  lock position prevents the calibration of the scale. Using a paper or wire seal will physically secure the switch if required.



Figure 4-1. Locking and Sealing the Calibration Lock Switch.

4.4 Weigh Below Feature

The Weigh Below Hook is stored inside the battery cover. Thread the hook into the access hole at the bottom of the scale. Mount the scale onto an appropriate assembly that allows free working space below the hook. See Figure 4-2. **Note:** Never allow the scale to rest directly on the Weigh Below Hook.

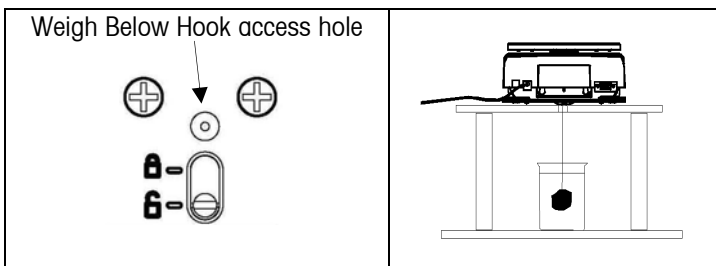

Figure 4-2. Setup for using the Weigh Below Hook.



5. MAINTENANCE

5.1 Troubleshooting

The following table lists common problems and possible causes and remedies. If the problem persists, contact your authorized dealer.

TABLE 5-1. TROUBLESHOOTING

Symptom	Possible Cause	Remedy
Cannot turn on	<ul style="list-style-type: none"> No power to scale Empty or incorrectly installed batteries 	<ul style="list-style-type: none"> Verify AC adapter connections and voltage. Replace batteries, check polarity.
Poor accuracy	<ul style="list-style-type: none"> Improper calibration Unstable environment Transportation Lock is set Debris touching the pan Draft shield is touching the pan or sample. 	<ul style="list-style-type: none"> Perform calibration. Move scale to suitable location. Slide the Lock pin to the unlocked position. Clean any debris next to or under the pan. Check that pan is fully seated, check sample height.
Cannot calibrate	<ul style="list-style-type: none"> Unstable environment Incorrect calibration mass. Transportation Lock is set Calibration Lock switch set to Locked position 	<ul style="list-style-type: none"> Move the scale to a suitable location. Use correct calibration masses. Slide the Lock pin to the unlocked position. Slide the Calibration Lock switch to the unlocked position.
Err 1	<ul style="list-style-type: none"> Invalid Checksum data. 	<ul style="list-style-type: none"> Cycle scale off/on. Contact an authorized dealer.

Symptom	Possible Cause	Remedy
Err 2	<ul style="list-style-type: none"> Over-load or Under-load condition. Transportation Lock is set Improper calibration 	<ul style="list-style-type: none"> Verify pan is installed and/or excess load is removed from pan. Slide the Lock pin to the unlocked position. Perform calibration.
Err 4	<ul style="list-style-type: none"> Invalid calibration mass. 	<ul style="list-style-type: none"> Verify correct calibration mass is being used.
Err 8	<ul style="list-style-type: none"> RS232 buffer is full. 	<ul style="list-style-type: none"> Cycle scale Off/On. Check RS232 settings in scale and computer when RS232 option is installed.
Err 9	<ul style="list-style-type: none"> Internal data error. 	<ul style="list-style-type: none"> Contact an authorized dealer.
 (Flashing)	<ul style="list-style-type: none"> Battery power is low. 	<ul style="list-style-type: none"> Replace batteries soon
	<ul style="list-style-type: none"> Battery power is too low for proper operation. 	<ul style="list-style-type: none"> Replace batteries

5.2 Service Information

If the troubleshooting section does not resolve or describe your problem, contact your authorized dealer.

6. TECHNICAL DATA

6.1 Specifications

TABLE 6-1. SPECIFICATIONS

Capacity (g)	100	300	150	300	300	500	900	1500	3000	5000	6000
Readability (g)	0.001	0.001	0.01	0.01	0.1	0.1	0.1	0.1	0.1	1	0.1
Linearity (d)	±3	±5	±1	±1	±1	±1	±1	±1	±1	±1	±2
Repeatability (g)	0.003	0.005	0.01	0.01	0.1	0.1	0.1	0.1	0.1	1	0.1
Span Mass (g)	100	200	100	200	200	300	500	1000	2000	3000	3000
Linearity Masses (g)	50 100	200 300	100 150	200 300	200 300	300 500	500 900	1000 1500	2000 3000	3000 5000	3000 5000
Weighing Units	Gram, Newton										
Tare Range	To Capacity by Subtraction										
Stabilization Time (sec)	< 3										
Operating Temperature Range	50° - 104°F / 10° - 40°C										
Operating Humidity Range	30%-90%										
Pan Size (mm)	90 dia.		120 dia.				123 x 124				

6.2. Accessories

TABLE 6-2. ACCESSORIES

AVAILABLE ACCESSORIES	
RS232 Interface Kit	Contact your authorized dealer to purchase required accessories.
USB interface Kit	
Specific Gravity kit	
Security Device	
Impact Printer	
Adapter, RS232 to Printer	
Auxiliary Display	
Calibration Masses	

6.3 Drawings

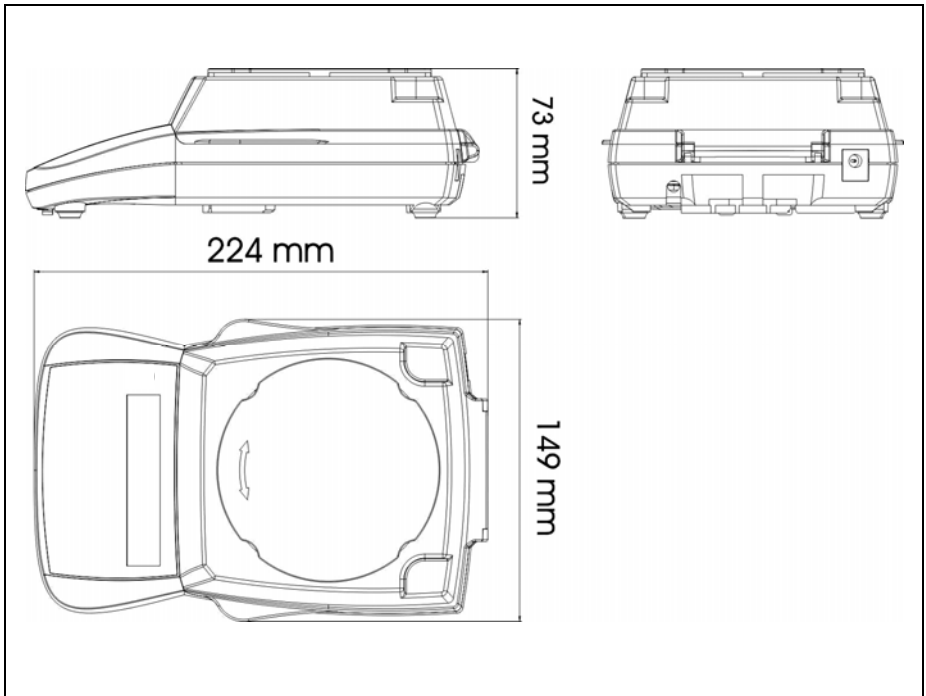

Figure 6-1. Overall Dimensions



* 8 0 2 5 1 7 1 7 *

P/N 80251717 A

Printed in China